



Änderungen vorbehalten!

Subject to change!

Modifications réservées!

Pos	Artikel/Article/Article	Basic									Pro									Art.-/SAP-No.	
		Heizspannung Heating voltage Tension de chauffage			Dampfleistung [kg/h] Steam capacity [kg/h]			Capacité de vapeur [kg/h]			Heizspannung Heating voltage Tension de chauffage			Dampfleistung [kg/h] Steam capacity [kg/h]			Capacité de vapeur [kg/h]				
		230V/1~	230V/3~	400V/3~	230V/3~	400V/3~	230V/3~	400V/3~	230V/3~	400V/3~	230V/1~	230V/3~	400V/3~	230V/3~	400V/3~	230V/3~	400V/3~	230V/3~	400V/3~		
100	Steuerelektronik Control PCB Unité de commande	1	1	1	1	1	1	1	1	1	1	1	1	1	1	1	1	1	1	1	2530128 2530130
101	Leistungssprint Power board Platine de puissance	1	1	1	1	1	1	1	1	1	1	1	1	1	1	1	1	1	1	1	2530144
102	Bedienpanel kpl. Control panel cpl. Panneau de commande cpl.	1	1	1	1	1	1	1	1	1	1	1	1	1	1	1	1	1	1	1	2530143
103	Folientastatur Keypad Clavier	1	1	1	1	1	1	1	1	1	1	1	1	1	1	1	1	1	1	1	2530135
104	Netzschalter Power switch Interrupteur du réseau	1	1	1	1	1	1	1	1	1	1	1	1	1	1	1	1	1	1	1	2530137
105	Betriebs- und Störungsfernmeldung Remote operation and fault indication Télésignalisation de travail et de dérangement	x	x	x	x	x	x	x	x	x	1	1	1	1	1	1	1	1	1	1	2529378
106	Schütz 230V, 50/60Hz Contactor 230V, 50/60Hz Contacteur 230V, 50/60Hz	25 A 50 A 65 A 80 A	1	1	1	1	1	1	1	1	1	1	1	1	1	1	1	1	1	1	1115507 1115511 1115809 1117502
107	Erdungsklemme Earth terminal Bloc de terre	10mm <sup>2</sup> 16mm <sup>2</sup>	1	1	1	1	1	1	1	1	1	1	1	1	1	1	1	1	1	1	2530794 2530795
108	Schlauchklemme ø21.0-22.0, 5 Stk. Hose clamp ø21.0-22.0, 5 pcs Pince à tuyau ø21.0-22.0, 5 pcs		x	x	x	x	x	x	x	x	x	x	x	x	x	x	x	x	x	x	2553596
110	Erdelektrode Earth electrode Electrode de terre		1	1	1	1	1	1	1	1	1	1	1	1	1	1	1	1	1	1	2530139
111	Schlauchset Einlass Hose set inlet Set de tuyau d'alimentation		1	1	1	1	1	1	1	1	1	1	1	1	1	1	1	1	1	1	2530186 2530187
112	Schlauchset Pumpe Hose set pump Set de tuyau pompe		1	1	1	1	1	1	1	1	1	1	1	1	1	1	1	1	1	1	2530188 2530189
113	Entleerungsschlauch Draining hose Tuyau de vidange		1	1	1	1	1	1	1	1	1	1	1	1	1	1	1	1	1	1	2530190 2530191
114	Schlauchklemme ø30.7-31.7, 5 Stk. Hose clamp ø30.7-31.7, 5 pcs Serre-joint pour tuyau ø30.7-31.7, 5 pcs		x	x	x	x	x	x	x	x	x	x	x	x	x	x	x	x	x	x	2519405
115	Schlauchklemme ø19.0-19.5, 5 Stk. Hose clamp ø19.0-19.5, 5 pcs Serre-joint pour tuyau ø19.0-19.5, 5 pcs		x	x	x	x	x	x	x	x	x	x	x	x	x	x	x	x	x	x	2519409
116	Schlauchklemme 30/9, 5 Stk. Hose clamp 30/9, 5 pcs Collier de serrage 30/9, 5 pcs		x	x	x	x	x	x	x	x	x	x	x	x	x	x	x	x	x	x	2522886
117	Einlassventil Inlet valve Vanne de remplissage	0.5 l/min. 1.2 l/min. 2.5 l/min.	1	1	1	1	1	1	1	1	1	1	1	1	1	1	1	1	1	1	2537275 2537276 2537277
118	Synchronpumpe kpl. Synchronous pump cpl. Pompe synchrone cpl.		1	1	1	1	1	1	1	1	1	1	1	1	1	1	1	1	1	1	1115532
119	Dichtring Pumpengehäuse Gasket for pump housing Joint pour boîtier de pompe		1	1	1	1	1	1	1	1	1	1	1	1	1	1	1	1	1	1	2550469

Pos	Artikel/Article/Article	Heizspannung Heating voltage Tension de chauffage	Basic								Pro								Art./SAP-No.																		
			230V/1~	230V/3~	400V/3~	230V/3~	400V/3~	230V/3~	400V/3~	230V/3~	400V/3~	230V/1~	230V/3~	400V/3~	230V/3~	400V/3~	230V/3~	400V/3~																			
			Dampfleistung [kg/h] Steam capacity [kg/h] Capacité de vapeur [kg/h]	5-8	5-8	5-8	9-15	9-15	16-21	16-25	22-30	26-45	5-8	5-8	5-8	9-15	9-15	16-21		16-25	22-30	26-45															
120	Kupplungsmuffe kpl. Coupling sleeve cpl. Manchon d'accouplement cpl.		1	1	1	1	1	1	1	1	1	1	1	1	1	1	1	1	1	1	1	1	1	1	1	1	1	1	1	1	1	1	1	1	1	2530176	
121	O-Ring, 10 Stk. O-ring seal, 10 pcs Joint O-ring, 10 pcs		x	x	x	x	x	x	x	x	x	x	x	x	x	x	x	x	x	x	x	x	x	x	x	x	x	x	x	x	x	x	x	x	x	1102867	
122	Wasserbecher kpl. Water cup cpl. Godet d'eau cpl.		1	1	1	1	1	1	1	1	1	1	1	1	1	1	1	1	1	1	1	1	1	1	1	1	1	1	1	1	1	1	1	1	1	1115542	
123	Ablaufbecher kpl. Drain cup cpl. Godet d'écoulement cpl.		1	1	1	1	1	1	1	1	1	1	1	1	1	1	1	1	1	1	1	1	1	1	1	1	1	1	1	1	1	1	1	1	1	1115534	
124	Dichtung Ablaufbecher Gasket drain cup Joint godet d'écoulement		1	1	1	1	1	1	1	1	1	1	1	1	1	1	1	1	1	1	1	1	1	1	1	1	1	1	1	1	1	1	1	1	1	2530424	
125	Ablaufstutzen kpl. Drain connection cpl. Manchon d'écoulement cpl.		1	1	1	1	1	1	1	1	1	1	1	1	1	1	1	1	1	1	1	1	1	1	1	1	1	1	1	1	1	1	1	1	1	1103890	
126	Schlauchklammerset Hose clip set Set serre-joint de tuyau		1	1	1	1	1	1	1	1	1	1	1	1	1	1	1	1	1	1	1	1	1	1	1	1	1	1	1	1	1	1	1	1	1	1115548	
127	PEX-Schlauchgarnitur PEX hose Tuyau PEX		1	1	1	1	1	1	1	1	1	1	1	1	1	1	1	1	1	1	1	1	1	1	1	1	1	1	1	1	1	1	1	1	1	1103857	
128	Dampfzylinderhalterung Cylinder fixing Fixation du cylindre	ø 22 mm ø 30 mm ø 45 mm	1	1	1			1	1									1	1																	2530331 2530332 2530333	
129	Blende Bezel Bandeau	ø33/140 ø42/140 ø60/140	1	1	1			1	1																											2530199 2530200 2530201	
130	Ausblasstutzen kpl. Steam outlet hose cpl. Manchon de vaporisation cpl.	ø22/ø30 ø30/ø30 ø42/ø45	x	x	x			x	x																											2530206 2530207 2530208	
131	Dampfschlauchanschluss kpl. Steam hose connection cpl. Raccord tuyau de vapeur cpl.	SC22 SC60 SC80	x	x	x			x	x																											2529363 2529364 2529365	
132	Dampfschlauchanschluss Steam hose connection Raccord tuyau de vapeur	ø 22 mm ø 30 mm ø 45 mm	x	x	x			x	x																											2530448 2530449 2530450	
133	Dampfschlauch Steam hose Tuyau de vapeur	DS22 (ø22/31mm) DS60 (ø30/40mm) DS80 (ø45/57mm)	x	x	x			x	x																											1105176 1103922 1102878	
134	Schlauchbride, 2 Stk. Screw hose clamp, 2 pcs Collier de serrage, 2 pcs	für / for / pour DS22 für / for / pour DS60 für / for / pour DS80	x	x	x			x	x																											1100432 2538894 2538898	
---	Kondensatschlauch Condensate hose Tuyau de condensat	KS10 (ø8/12mm)	x	x	x	x	x	x	x	x	x	x	x	x	x	x	x	x	x	x	x	x	x	x	x	x	x	x	x	x	x	x	x	x	1103350		
140	Verschluss kpl., 2 Stk. Door lock cpl., 2 pcs Fermeture cpl., 2 pcs		1	1	1	1	1	1	1	1	1	1	1	1	1	1	1	1	1	1	1	1	1	1	1	1	1	1	1	1	1	1	1	1	1	2530425	
141*	Gehäusetüre Housing door Porte du boîtier	Standard Standard INOX INOX	1	1	1	1	1			1	1	1	1																							2552898 2552900 2552903 2552904	
---	Gehäusetüre ohne Displayausschnitt (B-Gerät) Housing doorwithout display cutout (Unit B) Porte du boîtier sans découpe affichage (Appareil B)	Standard INOX																																		2552901 2552907	
142	Montage-Profil Mounting profile Support mural		x	x	x	x	x	x	x	x	x	x	x	x	x	x	x	x	x	x	x	x	x	x	x	x	x	x	x	x	x	x	x	x	x	2529544	
---	Kabel Steuerelektronik -> Leistungsprint Cable control PCB -> power board Câble unité de commande -> platine de puissance		1	1	1	1	1	1	1	1	1	1	1	1	1	1	1	1	1	1	1	1	1	1	1	1	1	1	1	1	1	1	1	1	1	1	2530238
---	Kabel Ventil + Pumpe Cable valve + pump Câble vanne + pompe		1	1	1	1	1																														2530239 2530240
---	Kabel RFI -> Steuerelektronik Cable RFI -> control PCB Câble RFI -> unité de commande		x	x	x	x	x	x	x	x	x	x	x	x	x	x	x	x	x	x	x	x	x	x	x	x	x	x	x	x	x	x	x	x	x	2568207	
---	Verbindungskabel (zwischen Gerät A und B) Connecting cable (between unit A and B) Câble de connexion (entre appareil A et B)	1.5m																																		2530335	

\* Lieferfrist ca. 6 Wochen / delivery time approx. 6 weeks / délai de livraison approx. 6 semaines

Pos	Artikel/Article/Article	Heizspannung Heating voltage Tension de chauffage	Basic								Pro								Art./SAP-No.			
			230V/1~		230V/3~		400V/3~		230V/3~		400V/3~		230V/3~		400V/3~							
			5-8	5-8	5-8	9-15	9-15	16-21	16-25	22-30	26-45	5-8	5-8	5-8	9-15	9-15	16-21	16-25		22-30	26-45	
Dampfleistung [kg/h] Steam capacity [kg/h] Capacité de vapeur [kg/h]		5-8	5-8	5-8	9-15	9-15	16-21	16-25	22-30	26-45	5-8	5-8	5-8	9-15	9-15	16-21	16-25	22-30	26-45			
--	Buskabel (zwischen Main und Extension) Bus cable (between Main and Extension) Câble bus (entre Main et Extension)	10m 20m																			1119115 1119116	
--	Sicherung, 3 Stk. Fuse, 3 pcs Fusible, 3 pcs	200mA F 6.3A T 100mA T 315mA F	x	x	x	x	x	x	x	x	x	x	x	x	x	x	x	x	x	x	2536024 2536025 2543802 2577833	
200	Sensorstecker mit Kabel Sensor plug with cable Fiche de connexion du senseur avec câble	ø 5mm	1	1	1	1	1	1	1	1	1	1	1	1	1	1	1	1	1	1	1115822	
201	Kabelbaum kpl. Cable tree cpl. Faisceau de câble cpl.		1		1			1			1		1			1		1		1	2530830 2530098 2530099 2530100 2530102 2530103	
202	Dampfzylinderstecker, 3 Stk. Cylinder plug, 3 pcs Fiche de connexion du cylindre, 3 pcs	ø 5mm ø 6mm	1	1	1	1	1	2	2	2	1	1	1	1	1	2	2	2	2	2	1102495 1101868	
203	Klammern zu reinigbarem Dampfzylinder, 4 Stk. Clip to cleanable steam cylinder, 4 pcs Clip pour cyl. à vapeur nettoiyable, 4 pcs		x	x	x	x	x	x	x	x	x	x	x	x	x	x	x	x	x	x	1115790	
204	O-Ring zu reinigbarem Dampfzylinder O-ring seal to cleanable steam cylinder O-ring pour cylindre à vapeur nettoiyable	D301 D401 D601	x	x	x		x	x			x	x	x		x	x			x	x	1115787 1115788 1115789	
205	Dichtungsring zu reinigbarem Dampfzylinder, 4 Stk. Seal ring to cleanable steam cylinder, 4 pcs Joint ring pour cylindre à vapeur nettoiyable, 4 pcs		x	x	x	x	x	x	x	x	x	x	x	x	x	x	x	x	x	x	1102225	
206	Elektroden-Set (ohne Schikane) Set electrodes (without divider) Set electrodes (sans chicane de separation)	E342 (D342) E343 (D343/363) E444 (D444/464) E644 (D644/664) E654 (D654/674)	1		1			1	1		1		1			1	1			1	1	1115779 1115780 1115781 1115782 1115783
207	Schikanen zu reinigbarem Dampfzylinder Divider to cleanable steam cylinder Chicane de séparation pour cylindre à vapeur nettoiyable	D363 D464 D664/674			x			x					x			x			x		1115784 1115785 1115786	
208	Sieb zu reinigbarem Dampfzylinder Strainer to cleanable steam cylinder Filtre de séparation pour cylindre à vapeur nettoiyable	3-600	x	x	x	x	x	x	x	x	x	x	x	x	x	x	x	x	x	x	1106695	
209	Austauschzylinder Exchange cylinder Cylindre à échanger	A342 A343 A363 A444 A464 A644 A654 A664 A674	1		1			1			1		1			1			1		5020006 5020007 5020010 5020012 5020014 5020021 5020022 5020024 5020025	
210	Reinigbare Zylinder mit Elektroden Cleanable steam cylinder with electrodes Cylindre nettoiyable avec électrodes	D342 D343 D363 D444 D464 D644 D654 D664 D674	x		x			x			x		x			x			x		5020032 5020033 5020036 5020037 5020038 5020039 5020040 5020041 5020042	
211	Reinigbarer Dampfzylinder (leer) Cleanable steam cylinder (empty) Cylindre à vapeur nettoiyable (vide)	D301 D401 D601	x	x	x		x	x			x	x	x		x	x			x	x	1115776 1115777 1115778	

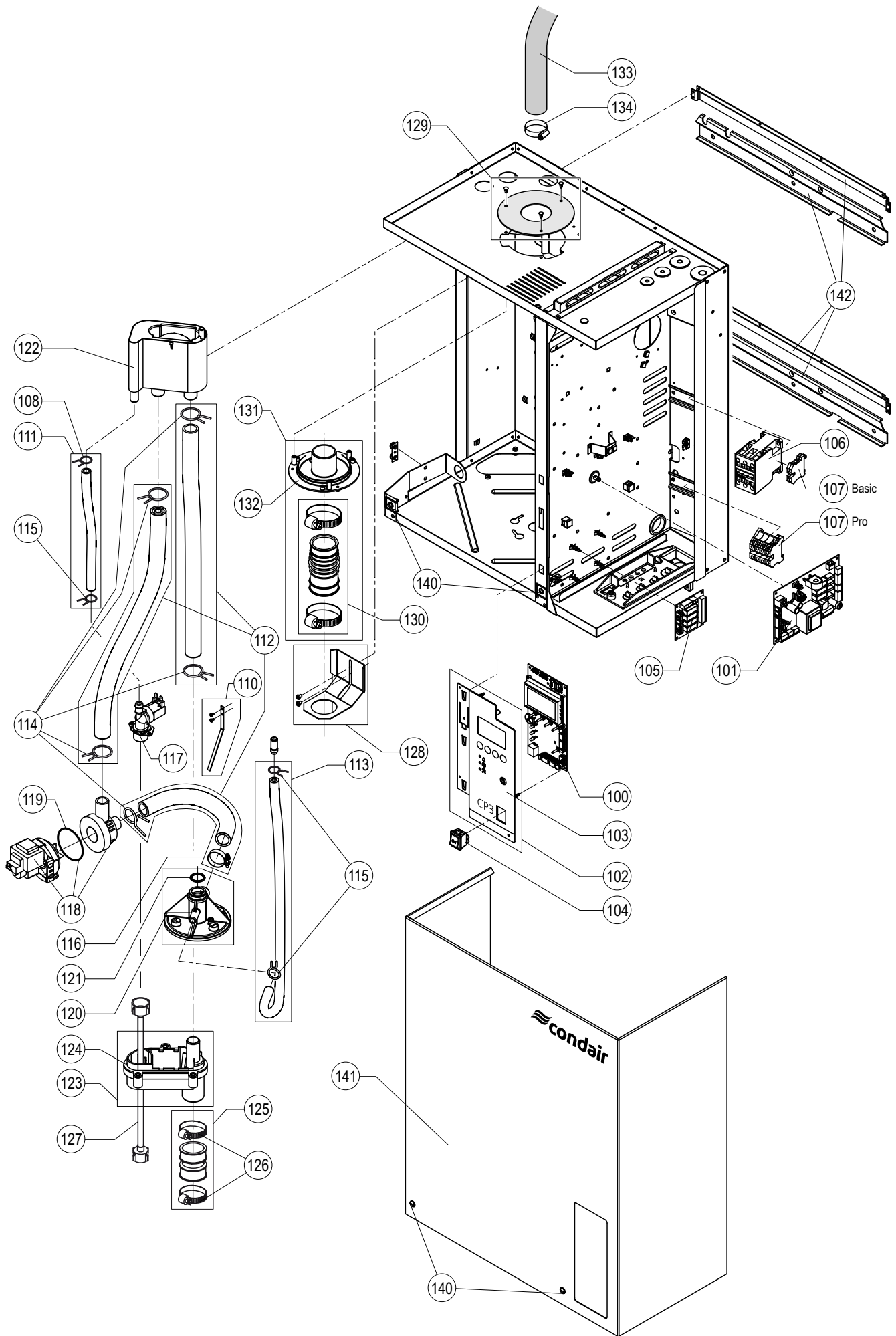

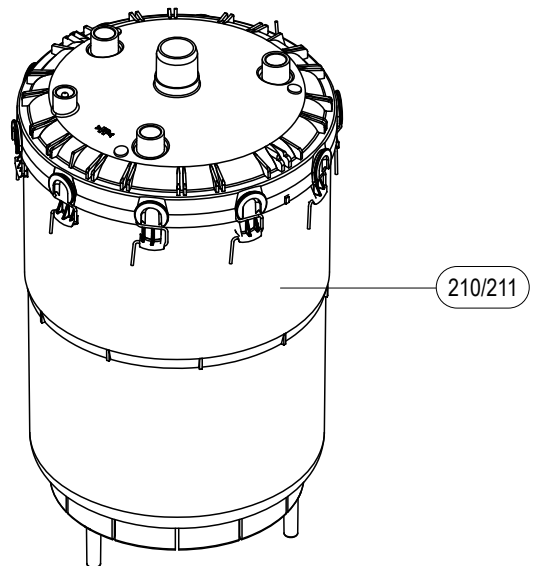
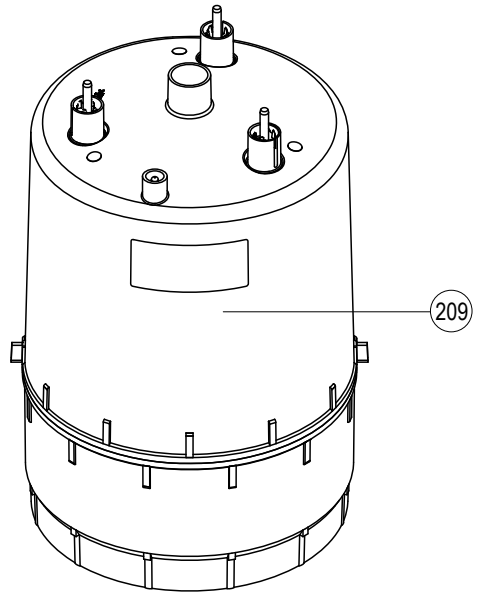
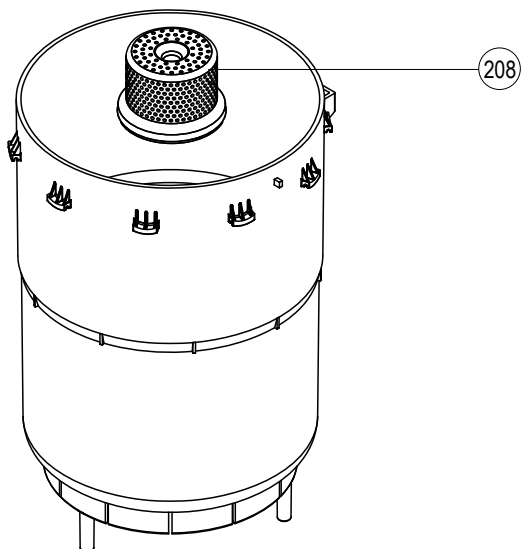
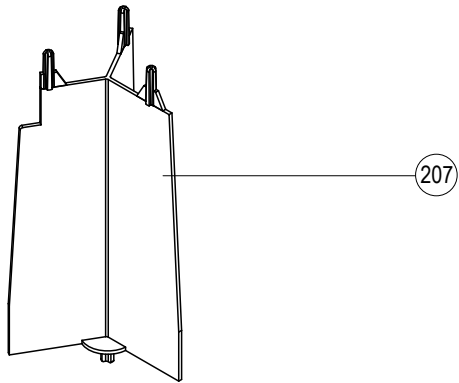
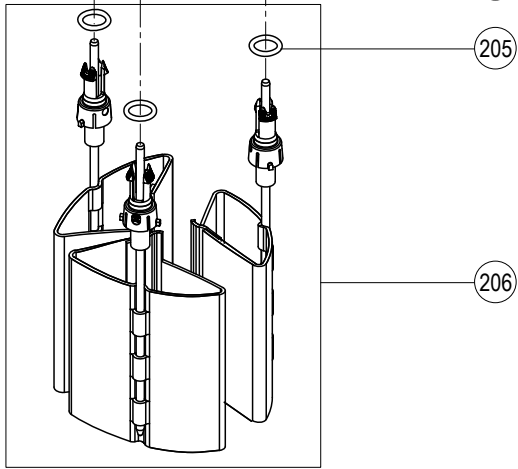
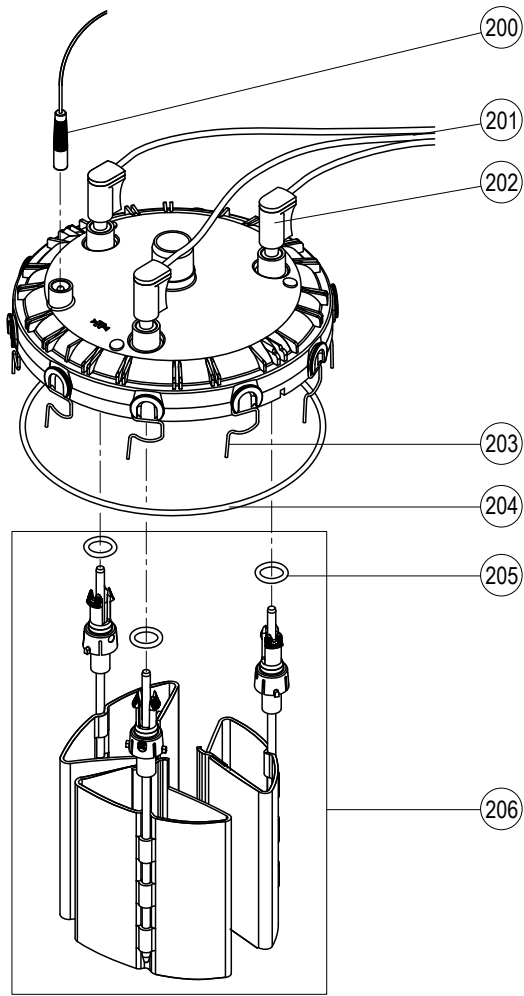



CH94/0002.00

Manufacturer:

Condair Operations GmbH

Schnackenburgallee 43-45

DE - 22525 Hamburg

Phone +49 40 52 47 266 16, Fax +49 40 52 47 266 30

info@condair.com, www.condair.com